

Chroma-Q[®] Inspire Mini[™] Terminal Strip

User Manual



Chroma-Q[®]
BRILLIANT SOLUTIONS

Part Number: CHINMINIHLRGBWE, CHINMINIHLRGBWEW
(Model: 632-6500, 632-6505)

Software Version (Engine) 2.2
Manual: 632-0711, V1.2 Jul 2019

Warranty Statement



Chroma-Q warrants to the original purchaser, with proof of purchase, that its delivered products shall be free from defects in material and workmanship under normal use for a period of 36 months from date of shipment.

Chroma-Q will repair, or at its option, provide an equivalent item or replace, the defective product during the stated warranty period. This warranty applies only to the repair or replacement of the product and only when the product is properly handled, installed and maintained according to Chroma-Q instructions. This warranty excludes defects resulting from improper handling, storage, installation, acts of God, fire, vandalism or civil disturbances. Purchaser must notify Chroma-Q in writing within 14 days of noticing the defect. This warranty excludes field labour or service charges related to the repair or replacement of the product.

The warranty contained herein shall not extend to any finished goods or spare parts from which any serial number has been removed or which have been damaged or rendered defective (a) as a result of normal wear and tear, wilful or accidental damage, negligence, misuse or abuse; (b) due to water or moisture, lightning, windstorm, abnormal voltage, harmonic distortion, dust, dirt, corrosion or other external causes; (c) by operation outside the specifications contained in the user documentation; (d) by the use of spare parts not manufactured or sold by Chroma-Q or by the connection or integration of other equipment or software not approved by Chroma-Q unless the Customer provides acceptable proof to Chroma-Q that the defect or damage was not caused by the above; (e) by modification, repair or service by anyone other than Chroma-Q, who has not applied for and been approved by Chroma-Q to do such modification, repair or service unless the Customer provides acceptable proof to Chroma-Q that the defect or damage was not caused by the above; (f) due to procedures, deviating from procedures specified by Chroma-Q or (g) due to failure to store, install, test, commission, maintain, operate or use finished goods and spare parts in a safe and reasonable manner and in accordance with Chroma-Q's instructions (h) by repair or replacement of engines without factory training.

The warranty contained herein shall not apply to finished goods or spare parts which are sold "as is", as "second-hand", as used", as "demo" or under similar qualifications or to Consumables ("Consumables" is defined as any part(s) of goods or part(s) for use with goods, which part(s) of goods or part(s) for use with goods are consumed during the operation of the goods and which part(s) of goods or part(s) for use with goods require replacement from time to time by a user such as, but not limited to, light bulbs).

The warranty contained herein shall not apply, unless the total purchase price for the defective finished goods or spare parts has been paid by the due date for payment.

The warranty contained herein applies only to the original purchaser and are not assignable or transferable to any subsequent purchaser or end-user.

This warranty is subject to the shipment of the goods, within the warranty period, to the Chroma-Q warranty returns department, by the purchaser, at the purchaser's expense. If no fault is found, Chroma-Q will charge the purchaser for the subsequent return of the goods.

Chroma-Q reserves the right to change the warranty period without prior notice and without incurring obligation and expressly disclaims all warranties not stated in this limited warranty.

Disclaimer

The information contained herein is offered in good faith and is believed to be accurate. However, because conditions and methods of use of our products are beyond our control, this information should not be used in substitution for customer's tests to ensure that Chroma-Q products are safe, effective, and fully satisfactory for the intended end use. Suggestions of use shall not be taken as inducements to infringe any patent. Chroma-Q sole warranty is that the product will meet the sales specifications in effect at the time of shipment. Your exclusive remedy for breach of such warranty is limited to refund of purchase price or replacement of any product shown to be other than as warranted.

Chroma-Q reserves the right to change or make alteration to devices and their functionality without notice due to our on going research and development.

The Chroma-Q Inspire Mini range has been designed specifically for the lighting industry. Regular maintenance should be performed to ensure that the products perform well in the entertainment environment.

If you experience any difficulties with any Chroma-Q products please contact your selling dealer. If your selling dealer is unable to help please contact support@chroma-q.com. If the selling dealer is unable to satisfy your servicing needs, please contact the following, for full factory service:

Outside North America:	North America:
Tel: +44 (0)1494 446000	Tel: 416-255-9494
Fax: +44 (0)1494 461024	Fax: 416-255-3514
support@chroma-q.com	support@chroma-q.com

For further information please visit the Chroma-Q website at www.chroma-q.com.

Chroma-Q and Inspire Mini are trademarks, for more information on this visit www.chroma-q.com/trademarks.

The rights and ownership of all trademarks are recognized.

Important Notice:

As per the requirements in the Occupational Safety and Health Administration standards for product approval, please refer to the OSHA web pages <http://www.osha.gov/dts/otpca/nrtl/> for information on the list of Nationally Recognized Testing Laboratories (NRTLs) and the scope of recognition.

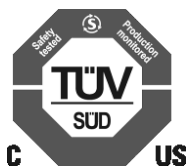

Safety information



WARNING!

Read the safety precautions in this section before installing, powering, operating or servicing



Warning!
Safety Hazard.
Risk of severe injury or death.



Warning!
Fire Hazard.

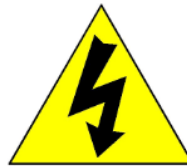

Warning!
Hazardous Voltage.
Risk of severe lethal electric shock.



Warning!
Refer to User manual.

Warning!

- Read the user manual before installing and operating the Chroma-Q Inspire Mini. For future reference, keep and use the manual.
- Safety precautions given in user manual must be followed at all times and the manuals of all the devices you connect it to. Observe all the warnings printed on devices and in manuals. Make sure whoever is involved in working on or using the Inspire Mini has carefully read and understood all the safety precautions and lasted warnings.
 - Install, connect, operate and service devices only as described in this manual and in connected devices' manuals and only in accordance with local laws and regulations. All Chroma-Q manuals are available for download from www.chroma-q.com.
 - Inspire Mini does not have user-serviceable parts. Refer any operation not described in this manual to support@chroma-q.com.

If you experience difficulties with any Chroma-Q products please contact your local dealer.

If your local dealer is unable to help then please contact support@chroma-q.com.

If you are having trouble finding what you are looking for on our website, then contact our Chroma-Q marketing department by sending an email to marketing@chroma-q.com.

PROTECTION FROM ELECTRIC SHOCK

- Use only the cables specified in this manual and on the Chroma-q website at www.chroma-q.com to interconnect devices in the installation. If the specified cables are not long enough for an intended cable run, consult Chroma-Q for assistance in finding or creating a safe alternative solution.
- Provide a means of locking out AC mains power that allows power to the installation to be shut down and made impossible to reapply, even accidentally, during work on the installation.
- Shut down power to the installation during service and when it is not in use.
- Before applying power to the installation, check that all power distribution equipment and cables are in perfect condition and rated for the current requirements of all connected devices.
- Isolate the installation from power immediately if any product, power cable or power plug is in any way damaged, defective or wet, or if it shows signs of overheating.
- Do not immerse an Inspire Mini fixture in water or expose it to high-pressure water jets.

PROTECTION FROM BURNS AND FIRE

- The Inspire Mini is cooled passively by natural air convection. Provide adequate clearance for airflow around the fixtures.
- Do not operate the Inspire Mini if the ambient temperature (T_a) exceeds 40°C (104°F).
- Do not modify the Inspire Mini in any way not described in this manual or install other than genuine Chroma-Q parts.
- Use only accessories approved by Chroma-Q.

PROTECTION FROM INJURY

- Ensure that the installation hardware and supporting surface or structure can hold at least 10 times the weight of all the devices they support.
- Block access below the work area and work from a stable platform whenever installing, servicing or moving the Inspire Mini.
- As soon as work is completed, check that all hardware and components are securely fastened to supporting structures.
- Make sure there are no flammable materials close to the product during operation.
- Avoid direct eye exposure to the light source while the product is on.
- Never try to repair the product. Repairs carried out by unskilled people can lead to damage or malfunction. Please contact the nearest authorized dealer or contact support@chroma-q.com.



Keep this User Manual for future consultation. If this product is used by another user, be sure that they also receive this document.

Table of Contents

1. Product overview	6
1.1 Inspire External Control Box	6
2. Operation.....	7
2.1 Unpacking the Units	7
2.2 Cabling system.....	7
2.3 Mounting.....	13
2.4 Optics	13
2.5 Control.....	13
2.6 Thermal Performance	13
2.7 Updating the LED engine software	14
3. Troubleshooting	15
4. Specification	16
4.1 Technical Specifications.....	16
4.2 Drawings – Dimensions	17
5. Maintenance.....	17

1. Product overview

The new Chroma-Q® Inspire Mini™ LED house light is a powerful and compact, multi-purpose creative lighting tool that compliments the award-winning Inspire Mini™ fixture. The Inspire Mini continues to utilise some of the innovative core technologies found in the incredibly popular Chroma-Q Color Force™ range. The fixture has a wide 65-degree beam angle and features a shorter housing designed for venues with low ceilings or balconies. The Inspire Mini provides a choice of beautiful whites, soft pastels and bold saturates - all from one fixture. By incorporating industry standard DMX-512 control to the external control box, the Inspire Mini is able to integrate seamlessly with an existing DMX infrastructure and can be controlled by any DMX supported lighting console. The Inspire Mini provides an excellent selection of stunning mixed colours and 'true' whites with no unsightly colour separation shadows. The Inspire Mini also features an energy-efficient LED design providing reduced maintenance and running costs.

The fixture is built with an internal power supply and controlled remotely from the Inspire External Control Box through the ANSI E1.11 USITT DMX 512-A protocol.

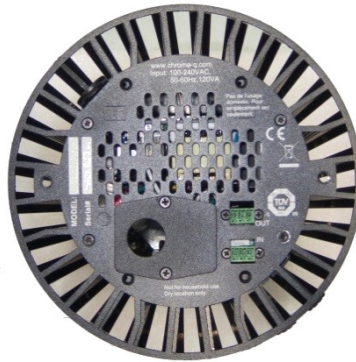

Note: HANDHELD light METERS

Handheld Light Meters provide a limited measuring range for LED fixtures, which may result in inconsistent and unreliable measurements.

All photometric values listed in this document are based on testing and measurements conducted by certified independent laboratories with reference to the IES standards.

1.1 Inspire External Control Box

The Inspire External Control Box is a 19" rack mount external remote addressing unit for the control of the Inspire Terminal Strip fixture via DMX 512.

Three data output ports are available for the control of 32+ daisy-chained fixtures from each port. (See cabling section for more details) DMX data input and through connections from an external DMX control console are via XLR 5-pin.

The Inspire External Control Box is built with Plug-in Terminal Block connectors for AC power input, Emergency power input, control data output signals and XLR DMX in and thru connections.



2. Operation

2.1 Unpacking the Units

The Inspire Mini Terminal Strip package includes:

ITEM	Description	Qty.	Model
1	Light Fixture	1	632-6XXX
2	Safety Chain	1	900-0649
3	Quick Start Guide	1	632-0712
4	Plug-in terminal blocks for DMX control data in/through	2	900-2212
5	Plug-in terminal block for AC power input	1	900-2214
6	Closing plate is included in the bag	1	632-0007

We recommend that you keep the original packaging in case the item needs to be returned

2.2 Cabling system

The Inspire External Control Box has 3 control data outputs (Port 1, 2, 3). Each control data output provides remote control for 32+ daisy-chained Inspire Terminal Strip fixtures. The maximum length of the DMX cable from each data output of the External Control Box to the first Terminal Strip fixture must not exceed 500 ft (152 m).

Each Inspire Terminal Strip fixture has its own signal buffer with a bypass relay. This means the signal transmitted from the UL924 Control box is being regenerated at each fixture. Therefore, the number of fixtures on a single link can exceed the typical 32 limits, in theories up to 128 fixtures could be daisy-chained. For ease of troubleshooting and to minimized the single point failure factor, it is suggested to divide the fixture count per link over the three outputs of the UL 924 Control box. In case of power failure on a fixture, an internal relay will let the data pass through.

It is also important to know that the signal coming out of the UL924 Control Box cannot be split using Y cables or DMX opto-splitter. However, Opto-Splitters or DMX buffer can be used to isolate links between fixture and control box.

Because the signal is being regenerated at each fixture, the first fixture on the link must have a 120 Ω resistor (terminator) between the + and – on the **input** side of the fixture.

If the cable length between the subsequent fixtures on the link is less than 100 feet (30 meters) no additional terminator is needed. If longer, a 120 Ω resistor can be added at the fixture data **input** where the longer cable connects.

Figure 1: System Diagram

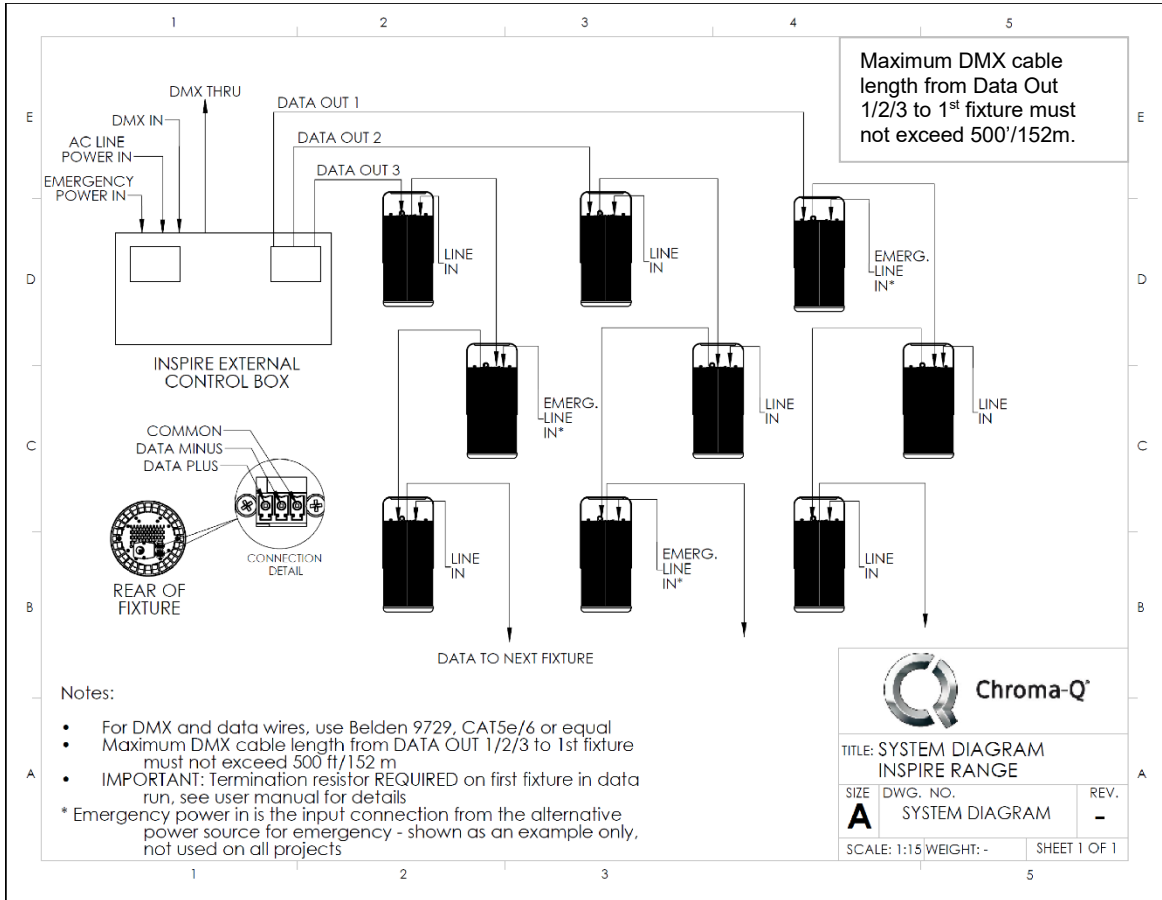

Inspire Mini Terminal Strip fixture wiring:

To connect the wiring of the AC power input cable:

1. There is a Power Input Cover Plate provided with the fixture (Figure 2), and is not attached to the fixture. The Power Input Cover Plate must be mounted as described in the following steps.
2. **To avoid pressure on connector and faulty connection, the power cable use should be soft like SJOW cable type. Avoid rigid electrical cable.**
3. Insert the power cable with the appropriate cable strain relief through the cover plate
4. Unplug the Terminal Block Plug from the Header and connect the wiring for the AC power input through the hole and into the Terminal Block PLUG (Figure 3)
5. Plug the wired Terminal Block Plug into the Terminal Block Header (Figure 3)
6. Put the cover plate on as shown in the picture and fasten the cover plate with the two screws provided with the light fixture

To connect the wiring of the control data cables:

1. Connect the wiring for the DMX control data cables (In/Out) into the Terminal Block Plugs (Figure 4)
2. The control cable connected to the **first** Inspire Terminal Strip fixture from each Data Output of the External Control Box **MUST** be terminated with a 120 Ω resistor. For details, see Inspire Terminal Strip DMX Cable Termination section on the next section.
3. Plug the wired Terminal Block Plugs into the Terminal Block Headers (Figure 4)

Note: The control cable connected to the **first** fixture from each data output **MUST** be terminated with a 120 Ω resistor. *Terminal blocks with resistors installed are included in the External Control Box.* See Inspire Terminal Strip Data Cable Termination on the next section.

Figure 2 Bottom view of the fixture

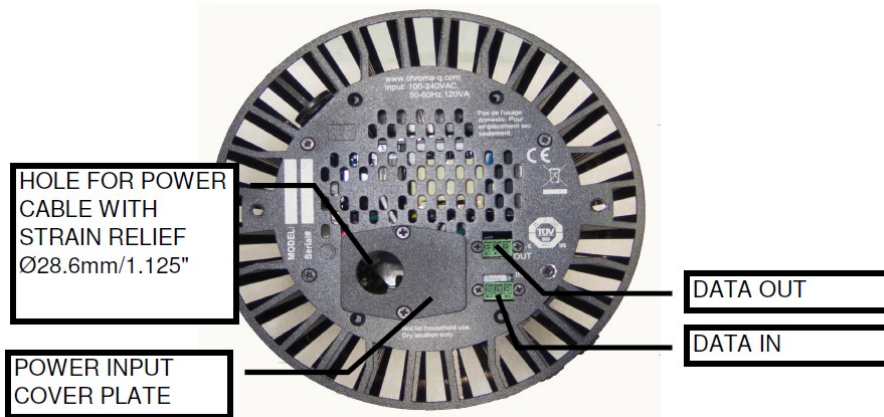

Figure 3: AC Power Cable Wiring

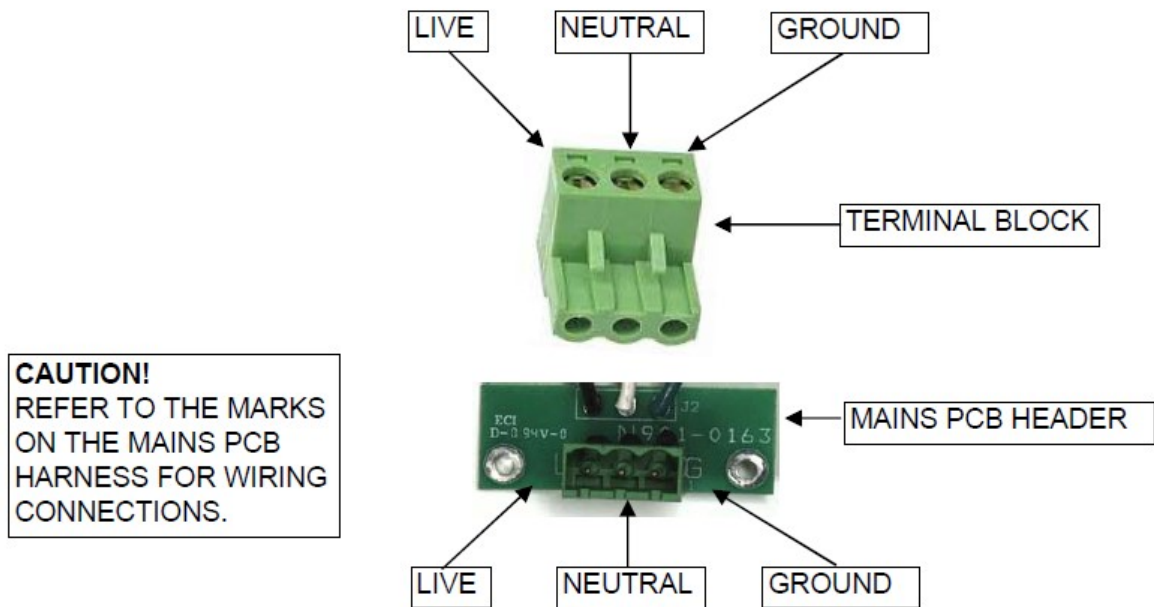
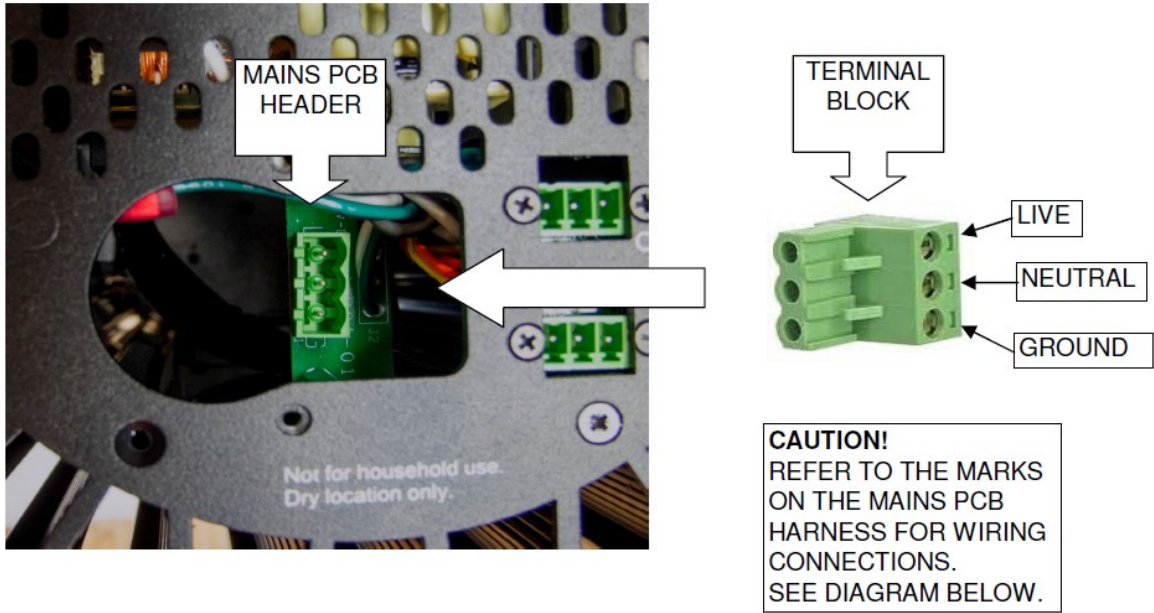
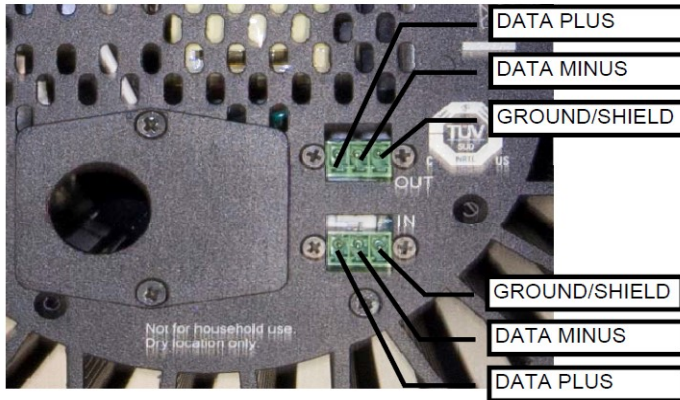

Figure 4: Data Cable Wiring



IMPORTANT! Inspire Terminal Strip Data Cable Termination:

The data cable connection from each Data Output of the External Control Box to the **first** Inspire Terminal Strip fixture **MUST** be terminated with a 120 Ω resistor. Insert a 120 Ω resistor into the Terminal Block Plug (Data Plus and Data Minus) and then plug into the data IN header of the **first** Inspire Terminal Strip fixture. (Figure 5 & 6)

Terminal blocks with resistors installed are included in the External Control Box.

Note: In order to eliminate line noise, be sure to terminate the data common wire.

Figure 5 Data Cable Termination

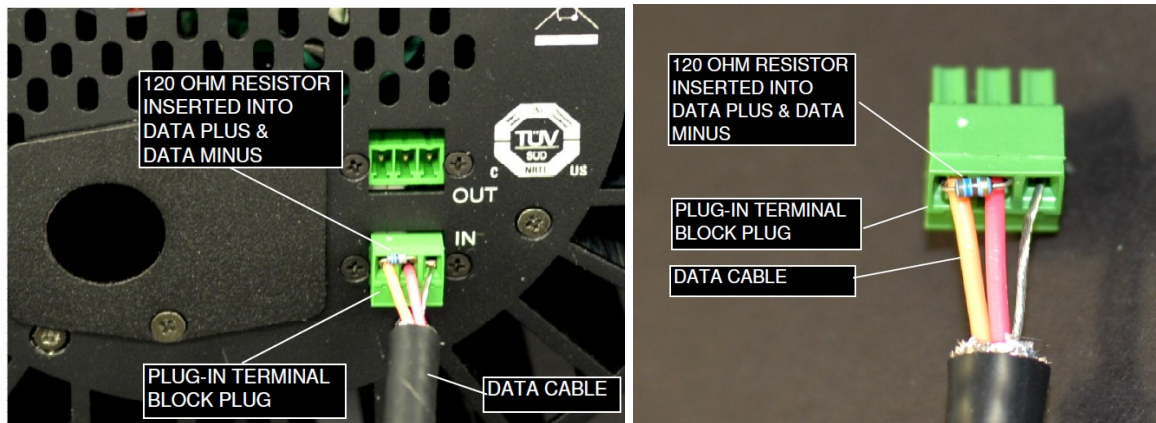

XLR 5-pin Cable:

Pin#	Function
1	Common (Screen)
2	Data Minus
3	Data Plus
4	Spare Data Minus
5	Spare Data Plus

Note: Refer to ESTA (Entertainment Services and Technology Association) technical standards program (TSP) documents (ANSI E1.27-2 -2009 (R2014)) for more detail about recommended practice for permanently installed control cables for use with ANSI E1.11 (DMX512-A) and USITT DMX512-1990 products or Click on the link below.

http://tsp.esta.org/tsp/documents/published_docs.php

Important Notice:

The maximum length of the DMX cable from each data output of the Inspire External Control Box to the first Terminal Strip fixture is 500 ft (152 m).

The use of an opto-splitter for DMX signal distribution is highly recommended when several control boxes are not plugged into the same power source.

Power Cable Color Code:

EU	North America	Connections	
Green and Yellow	Green	Earth (E)	Ground (Green)
Blue	White	Neutral (N)	Neutral (Silver)
Brown	Black	Live (L)	Hot (Gold)

Figure 6: Wire Stripping

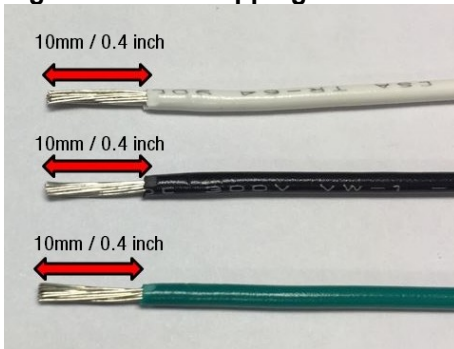

Stripping Wire: Remove a minimum of 10mm / 0.4 inch insulation off the 14 gauge wire before inserting into the phoenix connector.

To avoid short connections, keep some gap between the wire terminations to the connector. Once inserted, tighten the screws, then gently pull and make sure the connection is tight.

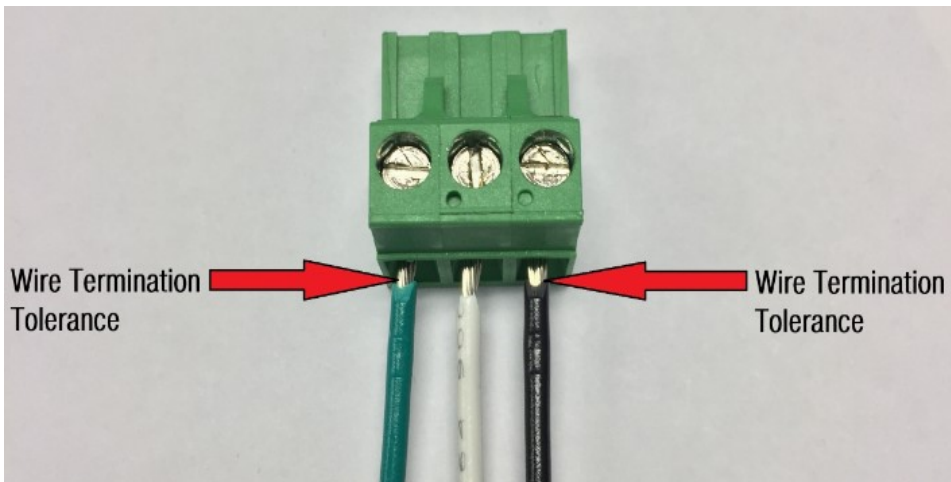





2.3 Mounting

The Inspire Terminal Strip fixture is built with a mounting bracket for overhead hanging applications. The mounting bracket has a 1/2" hole suitable for M10 & M12 bolts. Secure the fixture with a safety cable. A provision for a fixing hold is built into the fixture.

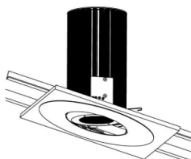
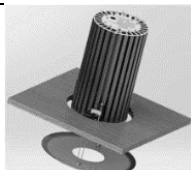
Other mounting options, such as a yoke, or recessing mounting kits are available. Consult your local representative or the Chroma-Q website for more details.

Optional Mounting Kits and Accessories

Picture	PART NUMBER: Description
	CHINSIK15B: Blind Sloped Ceiling Kit - 0 TO 15° Angle (Black Trim) CHINSIK15W: Blind Sloped Ceiling Kit - 0 TO 15° Angle (White Trim) CHINSIK30B: Blind Sloped Ceiling Kit - 20 TO 30° Angle (Black Trim) CHINSIK30W: Blind Sloped Ceiling Kit - 20 TO 30° Angle (White Trim)
	CQ632-9120: Inspire™ Blind Ceiling Mount Kit (Black Trim) CQ632-9121: Inspire™ Blind Ceiling Mount Kit (White Trim)
	CHINTHB: Inspire™ Top hat/Snoot (Black) CHINTHW: Inspire™ Top hat/Snoot (White)
	CHINBDB: Barndoor for Inspire™ (Black) CHINBDW: Barndoor for Inspire™ (White)
	CHINYK: Yoke Mount Kit for Inspire™ (Black) CHINYKW: Yoke Mount Kit for Inspire™ (White)

2.4 Optics

The Inspire Mini Terminal Strip fixture is built with Wide lens with a beam angle of approximately ~ 65°.

2.5 Control

The Inspire Mini Terminal Strip fixture is controlled remotely through the Inspire External Control Box via DMX protocol. For control menu details see the User Manuals for the Inspire External Control and Inspire External Control UL924 units.

2.6 Thermal Performance

The internal cooling system of the Inspire Terminal Strip is by convection and the fixture is built with automatic protection. The fixture's automatic protection reduces the output when the internal temperature reaches the maximum limit due to extreme ambient conditions.

2.7 Updating the LED engine software

The software for the LED engine module of the Terminal Strip can be uploaded directly into the fixture through the Uploader using an XLR5 to Terminal Block cable adaptor. The upload process can be performed to one fixture at a time only. (See diagram below)

1. Download and extract the “module_rgbw1_Inspire_v2.2.hex” from <http://www.chroma-q.com/support/downloads.asp> under the “Software” column.
2. Connect the Chroma-Q Uploader to your PC.
3. Erase the previous file and copy the “module_rgbw1_Inspire_v2.2.hex” into the Uploader.
4. Connect the Uploader to the fixture with a XLR 5-pin to Terminal Block cable adaptor.
5. Power-up the fixture.
6. The Uploader display shows the software name and version, and “Ready”.
7. Press the GO button once to execute the uploading.
8. The Red indicator light on the GO button blinks and the Uploader display shows a simulated arrow indicating the uploading process.
9. All the green LEDs of the fixture will light up (low intensity) to indicate completion of a successful Upload.
10. The Uploader display shows “DONE” upon completion of the upload.
11. Power-cycle the fixture.
12. Repeat step 6 to step 10 if the uploading process is interrupted (power and/or data).

(See the Quick Start Guide of the Chroma-Q Uploader)

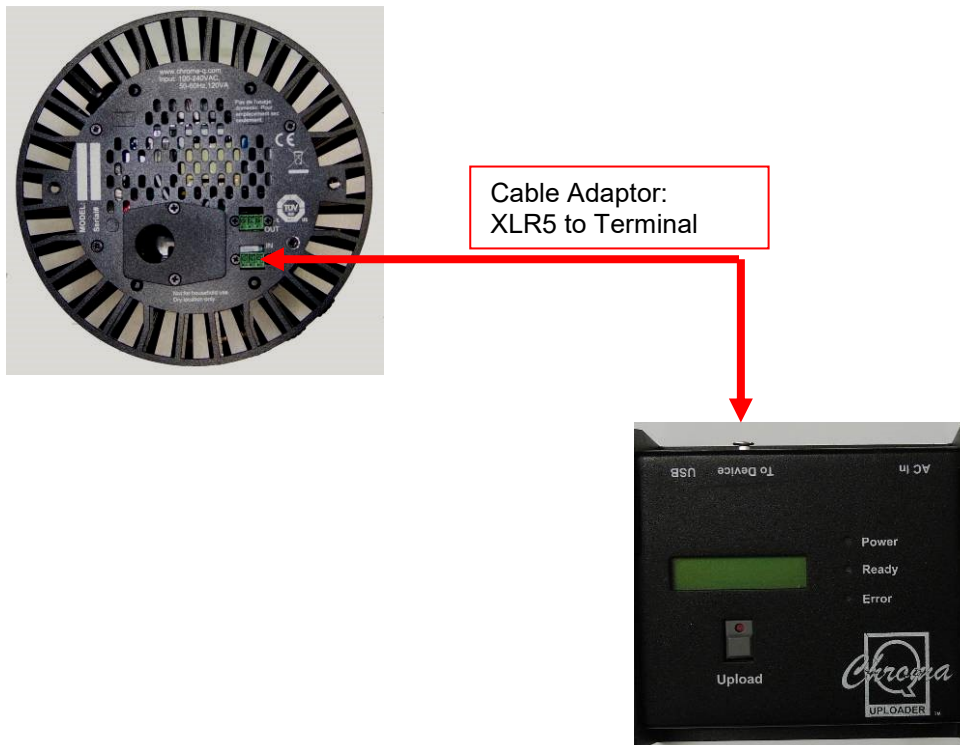

3. Troubleshooting

Troubleshooting is a process of elimination. First, rule out the other field factors (i.e. bad connections, faulty cables and power supplies). For technical support and/or parts, please contact your selling dealer or the offices listed in this manual.

Symptom	Possible Cause	Solution
Fixture does not respond to DMX control.	<ul style="list-style-type: none"> The External Control Box is set to the wrong or different DMX address. Bad cable connecting DMX control and External Control Box. Bad data cable connecting control box and fixture. Bad in/through connection between daisy-chained fixtures. Bad in/through connection between daisy-chained External Control Boxes. 	<ul style="list-style-type: none"> Check DMX address and Mode settings. Check/replace DMX run from the console to the External Control Box. Check/replace data runs from the External Control Box to the fixtures. Check/replace data runs between daisy-chained fixtures. Check/replace DMX runs between daisy-chained External Control Boxes.
Low LED output.	<ul style="list-style-type: none"> Internal temperature of the fixture is over the limit. 	<ul style="list-style-type: none"> Check area ventilation.
Flicker	<ul style="list-style-type: none"> No termination resistor 	<ul style="list-style-type: none"> Check the first fixture in each run if it has the 120 Ω terminating resistor.

4. Specification

4.1 Technical Specifications

Net Dimensions** (Without Fixings - Width x Height x Depth)	181mm x 251mm x 181mm / 7" x 10" x 7"
Net Weight (Without Fixings)	3kgs / 6.7lbs
Shipping Dimensions – Width x Height x Depth	310mm x 390mm x 310mm / 12.25" x 15.5" x 12.25"
Shipping Weight	4.5kgs / 10lbs
Power & Connections	
Power Supply	Built-in
Power Input Rating	100-240V AC 50-60Hz 120VA
Power Factor	0.9
Power Consumption	75W @ 120/230V AC (max.)
Inrush Current	32A @ 120V AC; 68A @ 230V AC
Idle Power Consumption	3.5W @ 120V AC; 5W @ 230V AC
Typical Power & Current	Measurements done with all LEDs at maximum intensity. Measurements made at nominal voltage. Allow for a deviation of +/- 10%.
Power connector Input	Terminal Block (use softer AC cable like SJOW type)
Data Connectors In/Out	Terminal Block: plug-in screw connector
Control Protocol	ANSI E1.11 USITT DMX 512-A
Cooling System	Convection
Operating Temperature	0°C to 40°C
Construction	Anodised aluminium extrusion
Colour	Black
Built-In Hardware	Mounting bracket
IP Rating	IP20
Approvals (Pending)	CISPR 22/EN55022 & CISPR 24/EN55024, ICES-003 Issue 4:2004 / FCC Part 15 Subpart B:2010, CSA C22.2 No. 166-M1983: R2008, UL 1573:2003 (R2010), IEC 60598-2-17
Control & Photometric	
LEDs	12 x Neutral White + 6 x RGB
LED Engines	1
LEDs Per Engine	30
Total LEDs	30
Control Modes	RGBW single, RGBW output, Tungsten, LookStore
Dimming Curve	Theatrical
Variable Effects Engine	Yes
Hot Lumen Output (Combined)	3010
Optics	Fully Homogenised
Beam Angle	65° (approx.)
Beam Distribution	Symmetrical direct illumination
CCT	Adjustable 1,000 – 10,000K
Colour Gamut	Performance enhanced
CRI	90
Lamp Life	L70 at 50,000 hours

**For exact measurements please refer to the line drawings below



4.2 Drawings – Dimensions

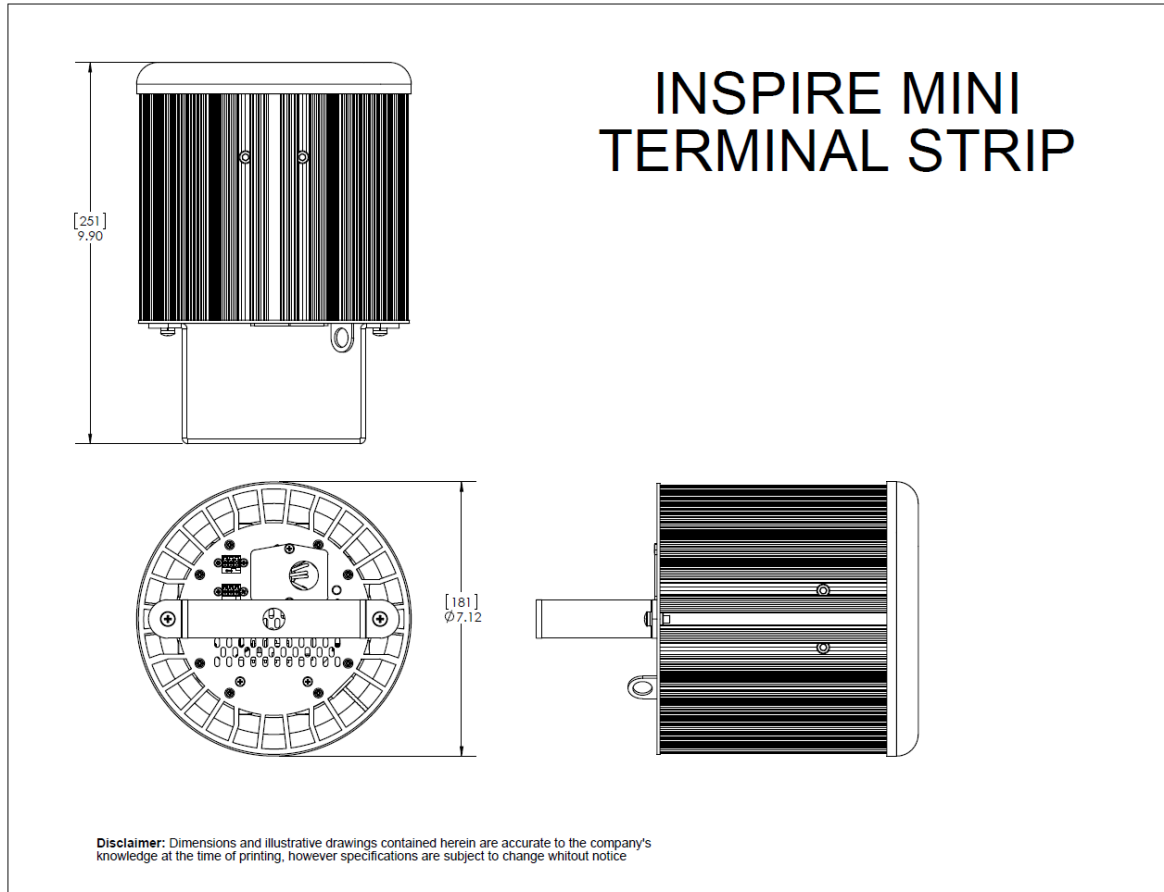

5. Maintenance

With care, the Inspire Mini Terminal Strip fixture and external control box requires little maintenance. However, as the unit is likely to be used in a stage environment, we recommend periodical internal inspection and cleaning of any resulting dust and cracked oil residue.

Do not spray liquids on the front or rear panel. If the front enclosure requires cleaning, wipe with a mild detergent on a damp cloth.