

Highlights:

- 9 x IEC C13 power outlet
- Male Schuko (CEE 7/7) input connection
- Black aluminum housing
- 2.5 meter cable
- Chassis earth connection point
- 16A ~ 250 VAC / 4000 W Max
- With illuminated switch
- Rotatable 19" mounting ears
- null



Product information:

The PSR1x9Ex are 19" power distribution units, compliant to the ANSI/EIA RS-310D, DIN41491 and IEC60297 standards. They come in three different models, without a switch (PSR109E), with an illuminated switch on the socket side (PSR109ES) or with an illuminated switch on opposite of socket side (PSR119ES). The construction is made using black powder coated aluminum fitted with steel 19" mounting ears on each side.

The total height covers a single 19" rackspace, allowing it to be installed in any 19" housing or equipment rack. Using the rotatable side ears, wall mounting is also made possible. Input connections are made using a fixed 2.5 meter connection cable fitted with a male schuko (CEE 7/7) plug, while IEC C13 output sockets allow power distribution to nine devices. A chassis earth connection point is provided for easily connecting your rack/enclosure to mains earth, as required by safety regulations.

Product Features:

Switch	Opposite side
Cable length	98.43 "
Unit height	1 HE
Dimensions	19 x 1.75 x 1.77 " (W x H x D)
Power handling	250 V AC ~ 16 A / 4000 W
Weight	1.76 lb

Physical Characteristics:

Inner conductor	Section	3 x 2.5 mm ²
-----------------	---------	-------------------------

Variants:

- PSR119ES/B - Black version

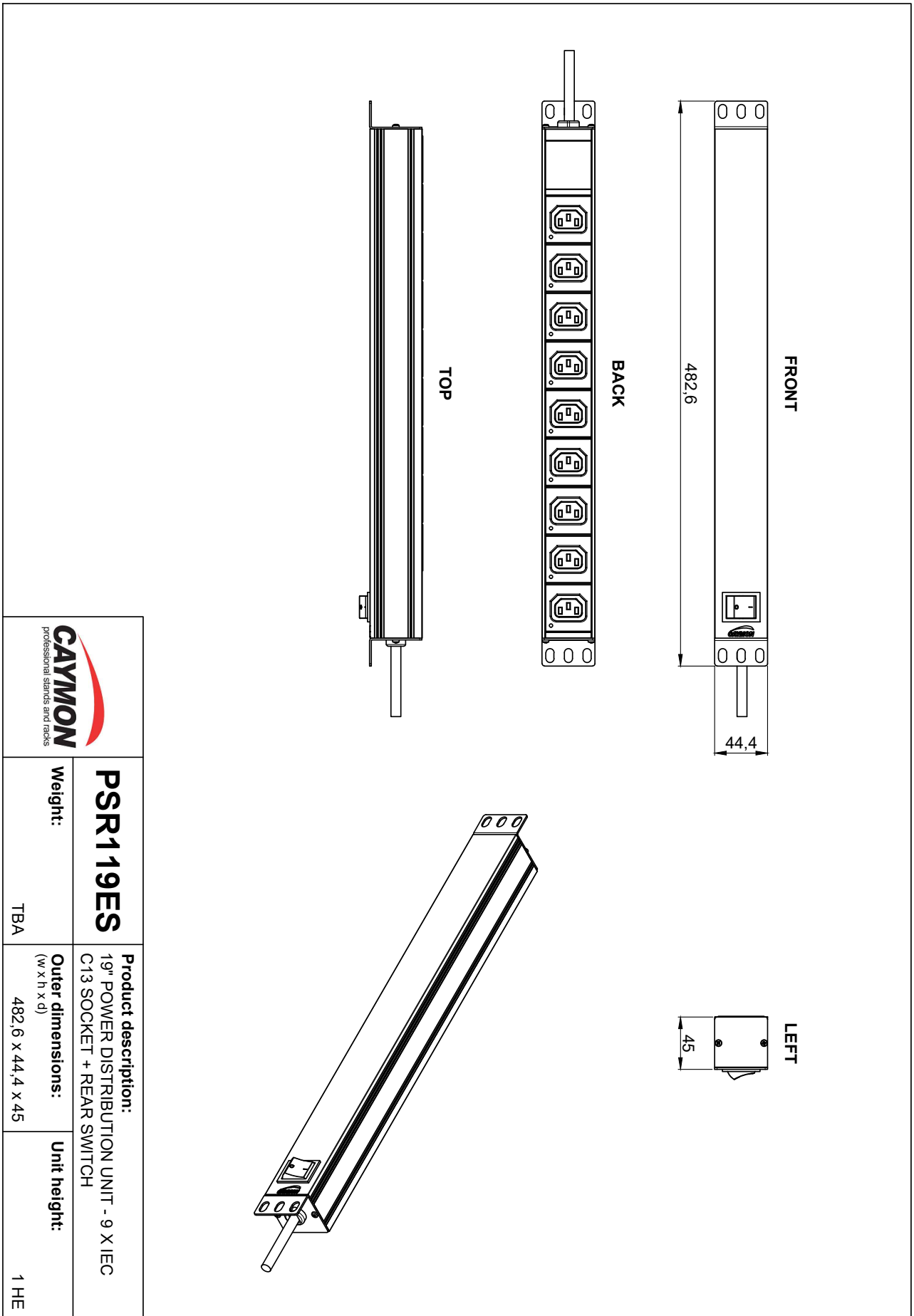

	PSR119ES	Product description: 19" POWER DISTRIBUTION UNIT - 9 X IEC C13 SOCKET + REAR SWITCH
	Weight: TBA	Outer dimensions: (w x h x d) 482,6 x 44,4 x 45